



Prec. No. _____

Rd. No. _____

2021 RIGHT OF WAY USE AND INDEMNIFICATION AGREEMENT

To Howard County Commissioners' Court
c/o Howard County Road & Bridge Engineer

Date _____

Formal notice is hereby given that _____, (Owner Company or Individual hereafter known as "Applicant"), proposes to contract with _____ ("Installer") to place

- An underground facility across a Howard County road. Refer to specification section I
- An underground facility parallel and inside a Howard County road (cannot be under travel way or clear zone). Refer to specification section I
- A temporary facility across the top of a Howard County road. Refer to specification section II
- A temporary facility parallel, inside, and on a Howard County road (cannot be under travel way or clear zone). Refer to specification section II
- A commercial driveway or temporary commercial driveway to a Howard County road. Refer to specification section III
- An overhead facility across a Howard County road. Refer to specification section IV
- An overhead facility parallel and inside a Howard County road. Refer to specification section IV

We will construct and maintain the above referenced line on the county right of way as shown on the attached drawing marked Exhibit A, and in accordance with the rules, regulations and policies of Howard County, and all governing laws, including but not limited to the "Texas Engineering Practice Act", "Federal Clean Water Act", the "National Endangered Species Act", "Americans with Disabilities Act", and the "Federal Historic Preservation Act". Upon request by Howard County Road & Bridge (HC R&B) at any time, we will submit to HC R&B proof of compliance with all governing laws, rules and regulations. **We understand that HC R&B does not purport hereby to grant any right, claim, title or easement in or upon county road right of way. We further certify that we have contacted and have the support of all adjoining land owners and understand that this document is subject to open records requests.**

We have read and will adhere to the specifications of the relevant section (I thru IV) for our facility and complete an application for each instance that our facility will be placed within Howard County's Right of Way. We understand that each instance requires the payment of **the \$400 non-refundable administration fee.**

WHEREAS, Howard County has consented to said operation by Applicant but seeks indemnification from said Applicant, their successors and assigns, from any and all liability which Howard County might hereinafter incur by reason of such road bore being constructed, operated, maintained, replaced or removed;

NOW, THEREFORE, KNOW ALL MEN BY THESE PRESENTS:

That Applicant, for good and valuable consideration, the receipt and sufficiency of which is hereby acknowledged, does hereby covenant and agree to fully indemnify and hold harmless Howard County, its agents, employees and elected officials, from any and all claims which might hereinafter be asserted against them, or any one of them, by any person, entity or governmental agency, premised upon allegations and/or claims that one or more of said Indemnities is liable and/or responsible, in whole or in part, for damages, demands, and/or causes of action with respect to damages to property, injury to or death of persons, livestock, or other living things, natural resource damages, CERCLA response costs, environmental remediation and restoration costs, or fines or penalties, arising out of or attributable to acts or omissions of Indemnitor in the construction, maintenance, operation or removal of said pipeline. Such indemnification by Applicant ("Indemnitor") of Howard County ("Indemnitee") shall include but not be limited to

claims asserting a violation of a failure to fulfill duties imposed by, or an incurrence of liability under, any Environmental Laws or under any principal of common law relating to duties to protect or not unduly disturb human health or environmental quality.

It is further agreed and understood that in the event it becomes necessary after the date of this agreement for the said county roadway to be widened or improved in any way, Applicant will indemnify Howard County for its expenses incurred in connection therewith for adjusting or moving the pipeline in the said county roadway so as to conform to the widened or improved road.

Applicant shall repair the roadway to the condition that existed prior to commencement of the work on or around the roadway; and in the event any of the cut sections of the identified County Road should sink or drop within a five-year period after the above mentioned repair of such section, the applicant will be responsible for all costs incurred in connection with the adjustment and repair of such sections.

Applicant understands and agrees that their work is subservient to the safety needs of the traveling public and will shut down any portion of the their facility or the entire project as directed by Howard County Road & Bridge until corrections can be made. Howard County Road & Bridge understands that the applicant has expenditures associated with stopping work and will utilize that option only when necessary.

By signing as/for the Applicant below, I certify that I am authorized to represent the Applicant, that my agreement to the provisions and requirements included in this Request, and that our commencement of construction will further attest to review and acceptance of said provisions and requirements.

Applicant (“Facility Owner” or agent with authority to sign for facility [i.e. pipe, power, etc. line owner])		
Date:		
By:		
Signature of Owner/ Owner’s Representative:		
Title:		
Address:		
City	State	Zip Code
Phone: () -		
Email:		

Approved by Howard County
Signature:
Brian J. Klinksiek, P.E., Road & Bridge Engineer
Date:

Check Here indicates - Additional requirements place by County after submission for permit to be valid. See Explanation Below:

Precinct: _____



Road _____

Final Insp. Date: _____ By: _____

Permit No. _____

Date: _____

Section II Temporary Facility Permit Application Modified 5-6-2021

Perpendicular Installation:

GLOBAL POSITION SYSTEM COORDINATES		
	LATITUDE	LONGITUDE
LOCATION		

Parallel Installation:

GLOBAL POSITION SYSTEM COORDINATES		
	LATITUDE	LONGITUDE
BEGIN		
END		

Contractor Prepared Application (Row Use agreement must be signed by an Owner/ Owner agent)

Permanent Responsible Contact Name (for problems in 1 + years **not the installer**): _____

Contact Email: _____ Contact Phone: _____

Underground Facility is being constructed for the purpose of: _____

County Use Only Below: Additional requirements for approval (check indicates required work):

- Applicant to reestablished vegetation
- Applicant use of culvert is less than 25% of culvert area

Verification Construction Requirements were met:

- All Driveways were bored by Applicant
- Applicant reestablished vegetation
- Applicant use of culvert is less than 25% of culvert area

Section II Aboveground Facility Specifications



-
1. **DESCRIPTION**
- Specification to construct a temporary perpendicular or parallel aboveground facility within the Right of Way of Howard County.
-
2. **FACILITY TYPES**
- 2.1. **Temporary Crossing Perpendicular to Roadway.** Facility (i.e. pipe line) will utilize an existing culvert and may not use more than 25% of culvert area. Complete Right of Way Use and Indemnification Agreement and Section II Permit Application. No additional required information to be attached. Facility layout appreciated
- 2.2. **Parallel to Roadway.** Facility (i.e. pipe line) must meet construction information below. Complete Right of Way Use and Indemnification Agreement and Section II Permit Application. No additional required information to be attached. Facility layout appreciated
-
3. **EQUIPMENT**
- Provide machinery, tools, and equipment necessary for proper execution of the work.
-
4. **CONSTRUCTION**
- 4.1. **Traffic Control.** Provide proper signage to include but not limit to “Road Work Ahead”, “Be Prepared To Stop”, “Stop” Signs as shown on the attached Manifold Crossing Traffic Control Plan. If signs are for day use only, folded over and remove from clear zone of Roadway (12 foot from edge of travel lane) each evening. If signs are to remain in place overnight they must meet criteria shown on sheets BC(4)-13 & BC(5-13). Failure to have proper signage is reason for Howard County to halt operations in its Right of Way. Applicant is responsible to monitor and maintain signs from weather, theft, vandalism etc.
- 4.2. **Driveways.** All driveways are to be bored. Trenching will **not** be allowed
- 4.3. **Parallel Facility Water Outfall.** Any aboveground facilities crossing a water outfall from the roadway must make arrangement with Howard County Road and bridge to avoid “damming” water in the event of a storm. These arrangements will be made on a case by case basis, however for the safety of the traveling public Howard County retains the right to remove the facility in the event that it causes an unsafe condition for motorists.
- 4.4. **Temporary Stockpiles.** Temporary stockpiles that are left in Howard County ROW must be delineated with reflective barrels. This includes stockpiles of tires left for machine crossings.
- 4.5. **Notification, Inspection, and Vegetation.** 24 hours before beginning work notify Howard County Road & Bridge Administration of the impending work at 432-264-2208. Howard County reserves the right to inspect the work for compliance to these specifications. After completing work reestablish vegetation to level similar to existing condition before work was started.

TYPICAL MINIMUM CLEARANCES FOR LONG TERM AND INTERMEDIATE TERM SIGNS

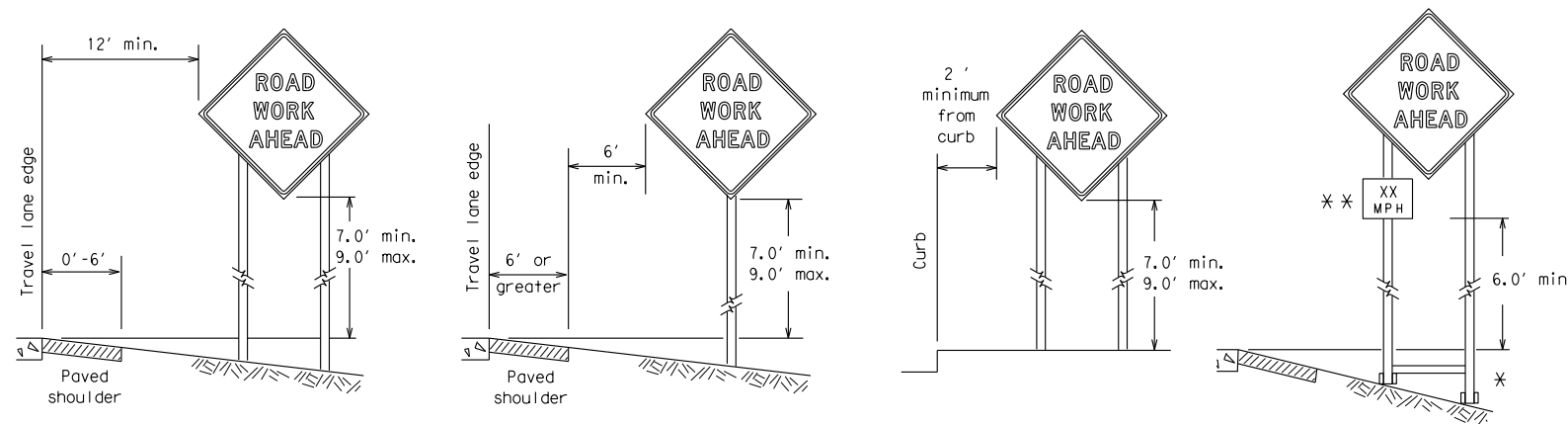

* When placing skid supports on unlevel ground, the leg post lengths must be adjusted so the sign appears straight and plumb. Objects shall NOT be placed under skids as a means of leveling.

** When plaques are placed on dual-leg supports, they should be attached to the upright nearest the travel lane. Supplemental plaques (advisory or distance) should not cover the surface of the parent sign.

ATTACHMENT FOR SIGN SUPPORTS

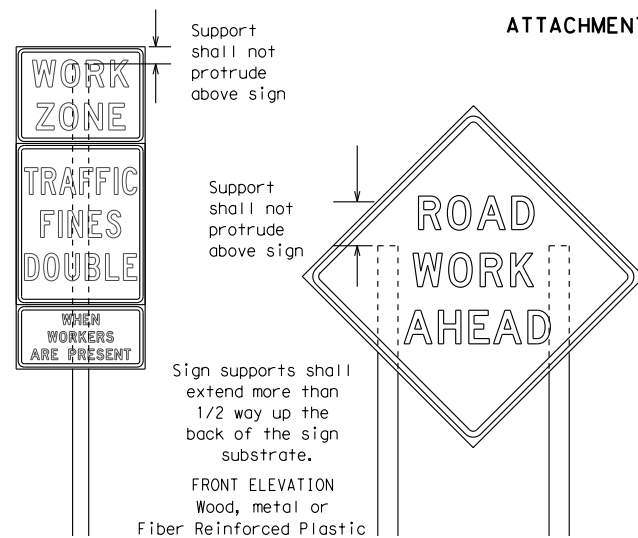

Attachment to wooden supports will be by bolts and nuts or screws. Use TxDOT's or manufacturer's recommended procedures for attaching sign substrates to other types of sign supports

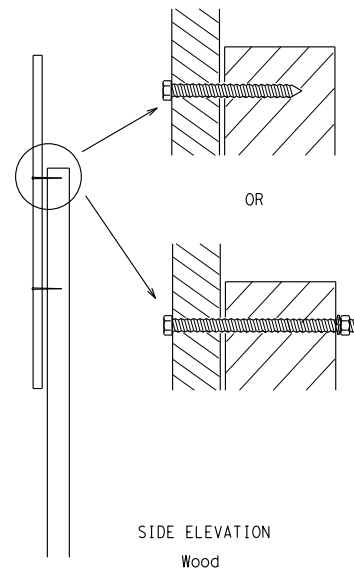

Nails shall NOT be allowed. Each sign shall be attached directly to the sign support. Multiple signs shall not be joined or spliced by any means. Wood supports shall not be extended or repaired by splicing or other means.

Splicing embedded perforated square metal tubing in order to extend post height will only be allowed when the splice is made using four bolts, two above and two below the splice point. Splice must be located entirely behind the sign substrate, not near the base of the support. Splice insert lengths should be at least 5 times nominal post size, centered on the splice and of at least the same gauge material.

STOP/SLOW PADDLES

- STOP/SLOW paddles are the primary method to control traffic by flaggers. The STOP/SLOW paddle size should be 24" x 24" as detailed below.
- When used at night, the STOP/SLOW paddle shall be retroreflectORIZED.
- STOP/SLOW paddles may be attached to a staff with a minimum length of 6' to the bottom of the sign.
- Any lights incorporated into the STOP or SLOW paddle faces shall only be as specifically described in Section 6E.03 Hand Signaling Devices in the TMUTCD.

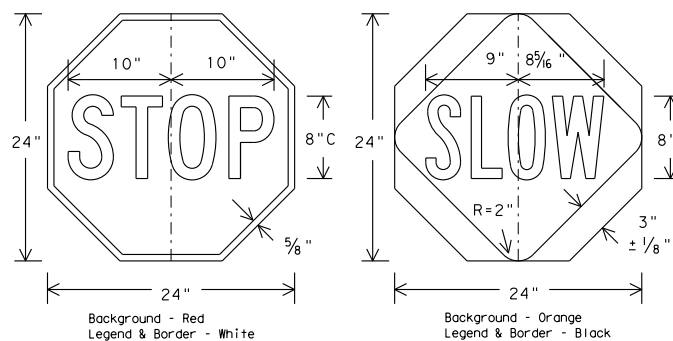

CONTRACTOR REQUIREMENTS FOR MAINTAINING PERMANENT SIGNS WITHIN THE PROJECT LIMITS

- Permanent signs are used to give notice of traffic laws or regulations, call attention to conditions that are potentially hazardous to traffic operations, show route designations, destinations, directions, distances, services, points of interest, and other geographical, recreational, or cultural information. Drivers proceeding through a work zone need the same, if not better route guidance as normally installed on a roadway without construction.
- When permanent regulatory or warning signs conflict with work zone conditions, remove or cover the permanent signs until the permanent sign message matches the roadway condition.
- When existing permanent signs are moved and relocated due to construction purposes, they shall be visible to motorists at all times.
- If existing signs are to be relocated on their original supports, they shall be installed on crashworthy bases as shown on the SMD Standard sheets. The signs shall meet the required mounting heights shown on the BC Sheets or the SMD Standards. This work should be paid for under the appropriate pay item for relocating existing signs.
- If permanent signs are to be removed and relocated using temporary supports, the Contractor shall use crashworthy supports as shown on the BC sheets or the CWZTCD. The signs shall meet the required mounting heights shown on the BC Sheets or the SMD Standards during construction. This work should be paid for under the appropriate pay item for relocating existing signs.
- Any sign or traffic control device that is struck or damaged by the Contractor or his/her construction equipment shall be replaced as soon as possible by the Contractor to ensure proper guidance for the motorists. This will be subsidiary to Item 502.

GENERAL NOTES FOR WORK ZONE SIGNS

- Contractor shall install and maintain signs in a straight and plumb condition and/or as directed by the Engineer.
- Wooden sign posts shall be painted white.
- Barricades shall NOT be used as sign supports.
- All signs shall be installed in accordance with the plans or as directed by the Engineer. Signs shall be used to regulate, warn, and guide the traveling public safely through the work zone.
- The Contractor may furnish either the sign design shown in the plans or in the "Standard Highway Sign Designs for Texas" (SHSD). The Engineer/Inspector may require the Contractor to furnish other work zone signs that are shown in the TMUTCD but may have been omitted from the plans. Any variation in the plans shall be documented by written agreement between the Engineer and the Contractor's Responsible Person. All changes must be documented in writing before being implemented. This can include documenting the changes in the Inspector's TxDOT diary and having both the Inspector and Contractor initial and date the agreed upon changes.
- The Contractor shall furnish sign supports listed in the "Compliant Work Zone Traffic Control Device List" (CWZTCD). The Contractor shall install the sign support in accordance with the manufacturer's recommendations. If there is a question regarding installation procedures, the Contractor shall furnish the Engineer a copy of the manufacturer's installation recommendations so the Engineer can verify the correct procedures are being followed.
- The Contractor is responsible for installing signs on approved supports and replacing signs with damaged or cracked substrates and/or damaged or marred reflective sheeting as directed by the Engineer/Inspector.
- Identification markings may be shown only on the back of the sign substrate. The maximum height of letters and/or company logos used for identification shall be 1 inch.
- The Contractor shall replace damaged wood posts. New or damaged wood sign posts shall not be spliced.

DURATION OF WORK (as defined by the "Texas Manual on Uniform Traffic Control Devices" Part 6)

- The types of sign supports, sign mounting height, the size of signs, and the type of sign substrates can vary based on the type of work being performed. The Engineer is responsible for selecting the appropriate size sign for the type of work being performed. The Contractor is responsible for ensuring the sign support, sign mounting height and substrate meets manufacturer's recommendations in regard to crashworthiness and duration of work requirements.
 - Long-term stationary - work that occupies a location more than 3 days.
 - Intermediate-term stationary - work that occupies a location more than one daylight period up to 3 days, or nighttime work lasting more than one hour.
 - Short-term stationary - daytime work that occupies a location for more than 1 hour in a single daylight period.
 - Short, duration - work that occupies a location up to 1 hour.
 - Mobile - work that moves continuously or intermittently (stopping for up to approximately 15 minutes.)

SIGN MOUNTING HEIGHT

- The bottom of Long-term/Intermediate-term signs shall be at least 7 feet, but not more than 9 feet, above the paved surface, except as shown for supplemental plaques mounted below other signs.
- The bottom of Short-term/Short Duration signs shall be a minimum of 1 foot above the pavement surface but no more than 2 feet above the ground.
- Long-term/Intermediate-term Signs may be used in lieu of Short-term/Short Duration signing.
- Short-term/Short Duration signs shall be used only during daylight and shall be removed at the end of the workday or raised to appropriate Long-term/Intermediate sign height.
- Regulatory signs shall be mounted at least 7 feet, but not more than 9 feet, above the paved surface regardless of work duration.

SIZE OF SIGNS

- The Contractor shall furnish the sign sizes shown on BC (2) unless otherwise shown in the plans or as directed by the Engineer.

SIGN SUBSTRATES

- The Contractor shall ensure the sign substrate is installed in accordance with the manufacturer's recommendations for the type of sign support that is being used. The CWZTCD lists each substrate that can be used on the different types and models of sign supports.
- "Mesh" type materials are NOT an approved sign substrate, regardless of the tightness of the weave.
- All wooden individual sign panels fabricated from 2 or more pieces shall have one or more plywood cleat, 1/2" thick by 6" wide, fastened to the back of the sign and extending fully across the sign. The cleat shall be attached to the back of the sign using wood screws that do not penetrate the face of the sign panel. The screws shall be placed on both sides of the splice and spaced at 6" centers. The Engineer may approve other methods of splicing the sign face.

REFLECTIVE SHEETING

- All signs shall be retroreflective and constructed of sheeting meeting the color and retro-reflectivity requirements of DMS-8300 for rigid signs or DMS-8310 for roll-up signs. The web address for DMS specifications is shown on BC(1).
- White sheeting, meeting the requirements of DMS-8300 Type A, shall be used for signs with a white background.
- Orange sheeting, meeting the requirements of DMS-8300 Type B_{FL} or Type C_{FL}, shall be used for rigid signs with orange backgrounds.

SIGN LETTERS

- All sign letters and numbers shall be clear, and open rounded type uppercase alphabet letters as approved by the Federal Highway Administration (FHWA) and as published in the "Standard Highway Sign Design for Texas" manual. Signs, letters and numbers shall be of first class workmanship in accordance with Department Standards and Specifications.

REMOVING OR COVERING

- When sign messages may be confusing or do not apply, the signs shall be removed or completely covered.
- Long-term stationary or intermediate stationary signs installed on square metal tubing may be turned away from traffic 90 degrees when the sign message is not applicable. This technique may not be used for signs installed in the median of divided highways or near any intersections where the sign may be seen from approaching traffic.
- Signs installed on wooden skids shall not be turned at 90 degree angles to the roadway. These signs should be removed or completely covered when not required.
- When signs are covered, the material used shall be opaque, such as heavy mil black plastic, or other materials which will cover the entire sign face and maintain their opaque properties under automobile headlights at night, without damaging the sign sheeting.
- Burlap shall NOT be used to cover signs.
- Duct tape or other adhesive material shall NOT be affixed to a sign face.
- Signs and anchor stubs shall be removed and holes backfilled upon completion of work.

SIGN SUPPORT WEIGHTS

- Where sign supports require the use of weights to keep from turning over, the use of sandbags with dry, cohesionless sand should be used.
- The sandbags will be tied shut to keep the sand from spilling and to maintain a constant weight.
- Rock, concrete, iron, steel or other solid objects shall not be permitted for use as sign support weights.
- Sandbags should weigh a minimum of 35 lbs and a maximum of 50 lbs.
- Sandbags shall be made of a durable material that tears upon vehicular impact. Rubber (such as tire inner tubes) shall NOT be used.
- Rubber ballasts designed for channelizing devices should not be used for ballast on portable sign supports. Sign supports designed and manufactured with rubber bases may be used when shown on the CWZTCD list.
- Sandbags shall only be placed along or laid over the base supports of the traffic control device and shall not be suspended above ground level or hung with rope, wire, chains or other fasteners. Sandbags shall be placed along the length of the skids to weigh down the sign support.
- Sandbags shall NOT be placed under the skid and shall not be used to level sign supports placed on slopes.

FLAGS ON SIGNS

- Flags may be used to draw attention to warning signs. When used the flag shall be 16 inches square or larger and shall be orange or fluorescent red-orange in color. Flags shall not be allowed to cover any portion of the sign face.

SHEET 4 OF 12



BARRICADE AND CONSTRUCTION TEMPORARY SIGN NOTES

BC (4) - 14

FILE: bc-14.dgn	DN: TxDOT	CK: TxDOT	DW: TxDOT	CK: TxDOT
© TxDOT November 2002	CONT	SECT	JOB	HIGHWAY
REVISIONS				
9-07 8-14				
7-13	DIST	COUNTY		SHEET NO.

DISCLAIMER: The use of this standard is governed by the "Texas Engineering Practice Act". No warranty of any kind is made by TxDOT for any purpose whatsoever. TxDOT assumes no responsibility for the conversion of this standard to other formats or for incorrect results or damages resulting from its use.

DATE: FILE:

DISCLAIMER: The use of this standard is governed by the "Texas Engineering Practice Act." No warranty of any kind is made by TxDOT for any purpose whatsoever. TxDOT assumes no responsibility for the conversion of this standard to other formats or for incorrect results or damages resulting from its use.

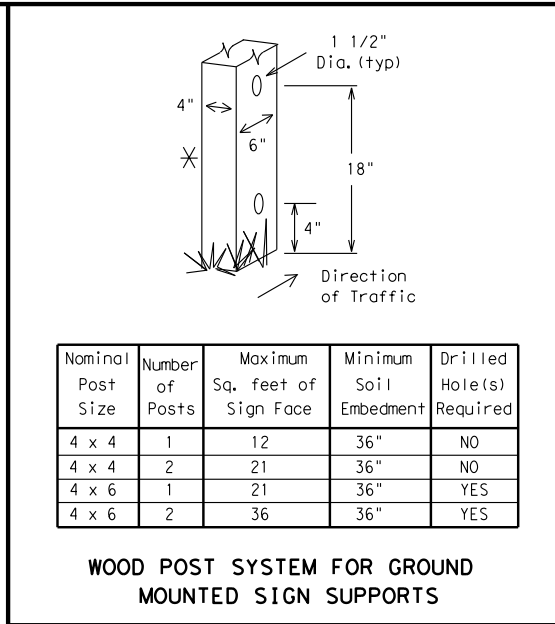
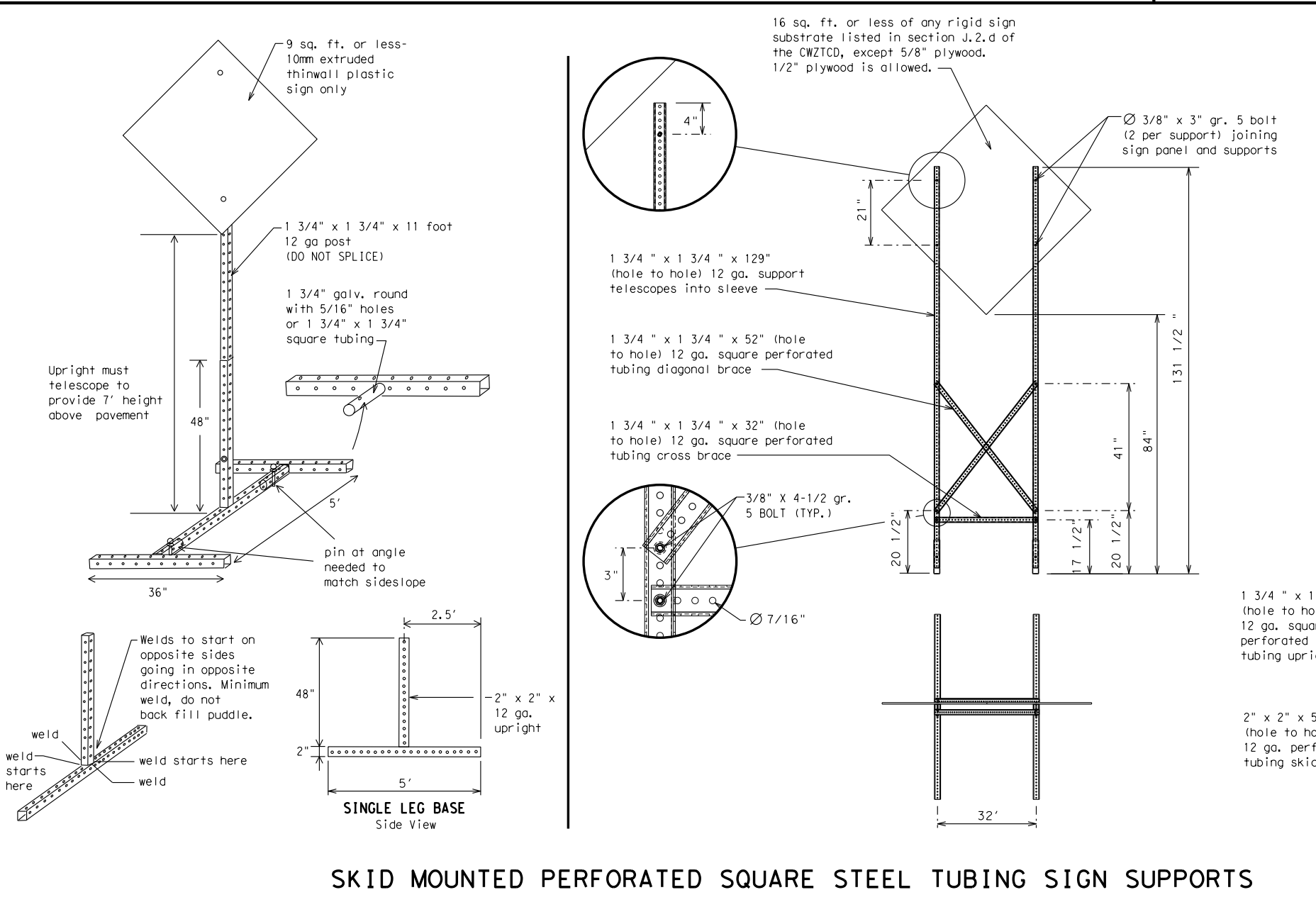
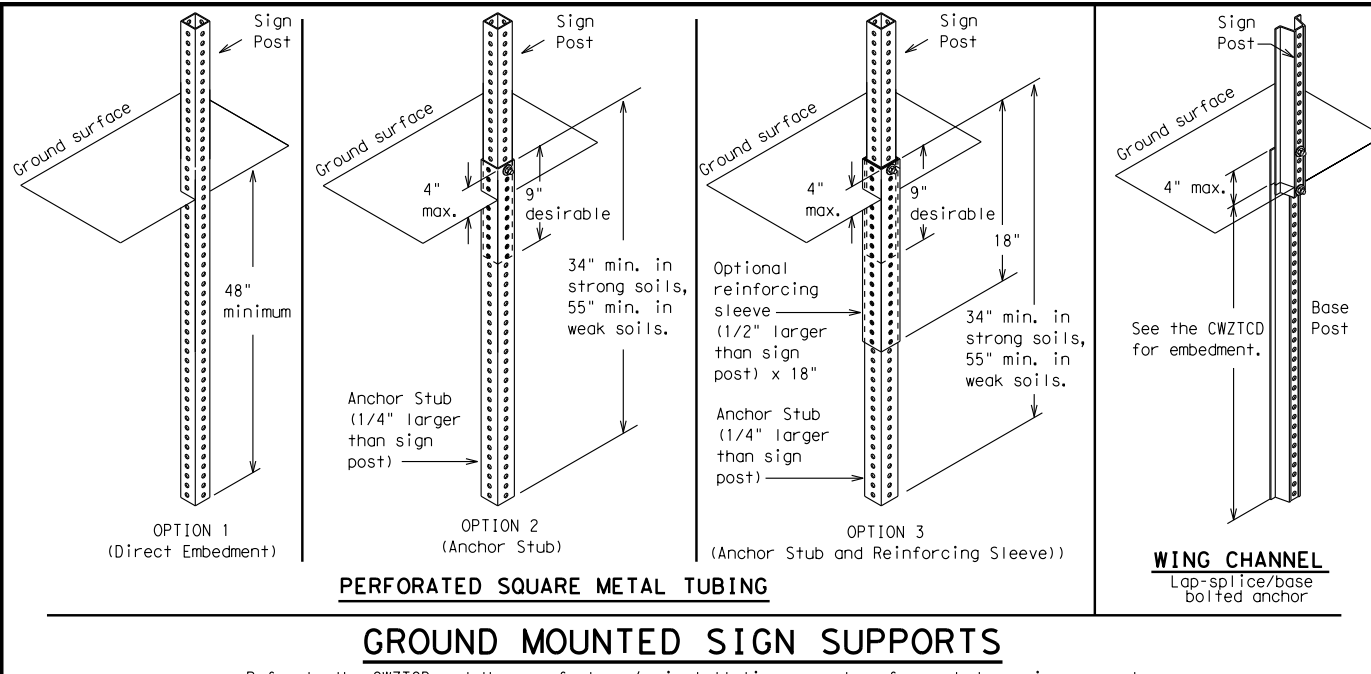
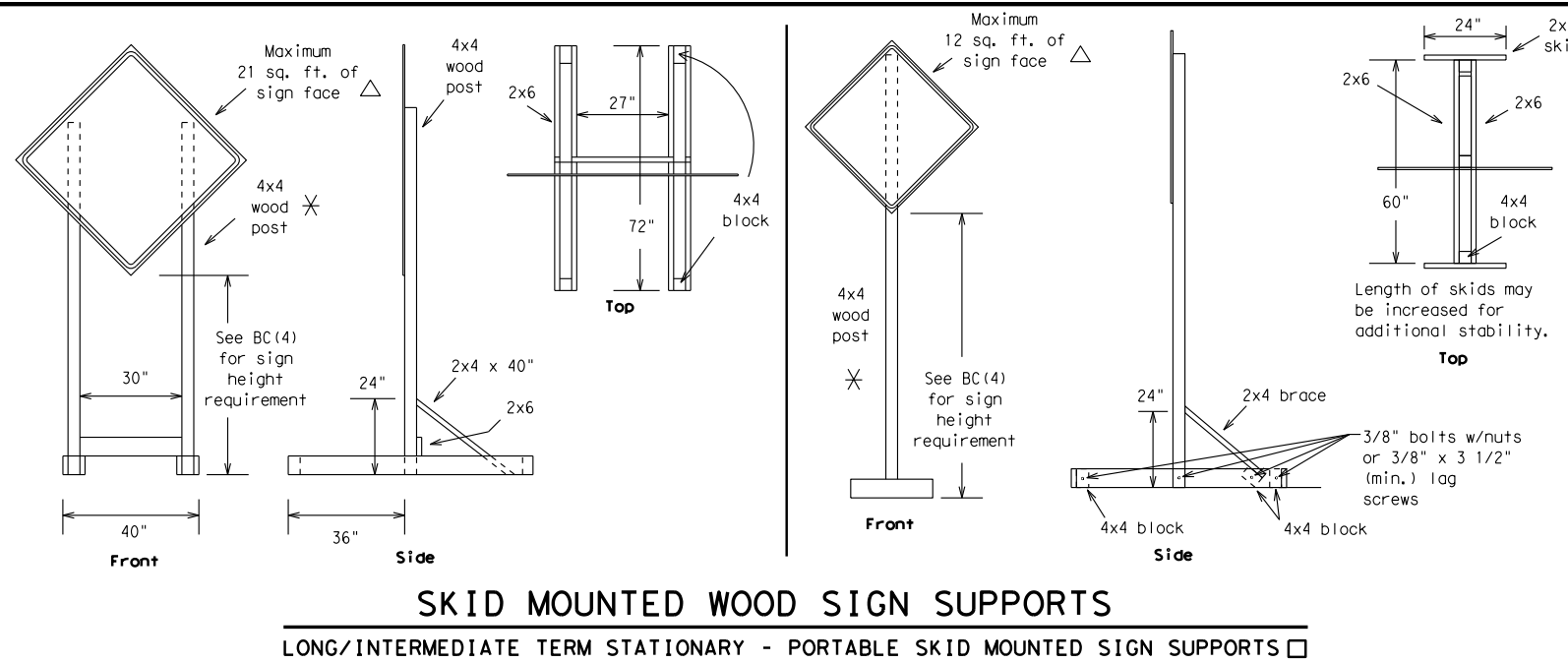

WEDGE ANCHORS
Both steel and plastic Wedge Anchor Systems as shown on the SMD Standard Sheets may be used as temporary sign supports for signs up to 10 square feet of sign face. They may be set in concrete or in sturdy soils if approved by the Engineer. (See web address for "Traffic Engineering Standard Sheets" on BC(1)).

OTHER DESIGNS
MORE DETAILS OF APPROVED LONG/INTERMEDIATE AND SHORT TERM SUPPORTS CAN BE FOUND ON THE CWZTCD LIST. SEE BC(1) FOR WEBSITE LOCATION.

GENERAL NOTES

- Nails may be used in the assembly of wooden sign supports, but 3/8" bolts with nuts or 3/8" x 3 1/2" lag screws must be used on every joint for final connection.
- No more than 2 sign posts shall be placed within a 7 ft. circle, except for specific materials noted on the CWZTCD List.
- When project is completed, all sign supports and foundations shall be removed from the project site. This will be considered subsidiary to Item 502.

See BC(4) for definition of "Work Duration."
 Wood sign posts MUST be one piece. Splicing will NOT be allowed. Posts shall be painted white.
 See the CWZTCD for the type of sign substrate that can be used for each approved sign support.

SHEET 5 OF 12
Texas Department of Transportation
Traffic Operations Division Standard

BARRICADE AND CONSTRUCTION TYPICAL SIGN SUPPORT

BC(5) - 14

FILE: bc-14.dgn	DN: TxDOT	CK: TxDOT	DW: TxDOT	CK: TxDOT
© TxDOT November 2002	CONT	SECT	JOB	HIGHWAY
REVISIONS				
9-07	8-14			
7-13				
	DIST	COUNTY		SHEET NO.

DATE: FILE: